

PART NUMBER: CPE-164

DESCRIPTION: piezo audio transducer

SPECIFICATONS

operating voltage	20 Vp-p max.	
current consumption	10 mA max.	at 10 Vp-p, sqare wave, 4.0 Khz
sound pressure level	80 db min.	at 10 cm/10 Vp-p, sqare wave, 4.0 Khz
electrostatic capacity	16,000 ± 30%	at 1 KHz/1 V
operating temperature	-20 ~ +70° C	
storage temprature	-30 ~ +80° C	
dimensions	Ø13.7 x H7.6 mm	
weight	0.9 g max.	
material	NORYL (black)	
terminal	pin type (Au plating)	
RoHS	yes	

APPEARANCE DRAWING

tolerance: ±0.5
units: mm

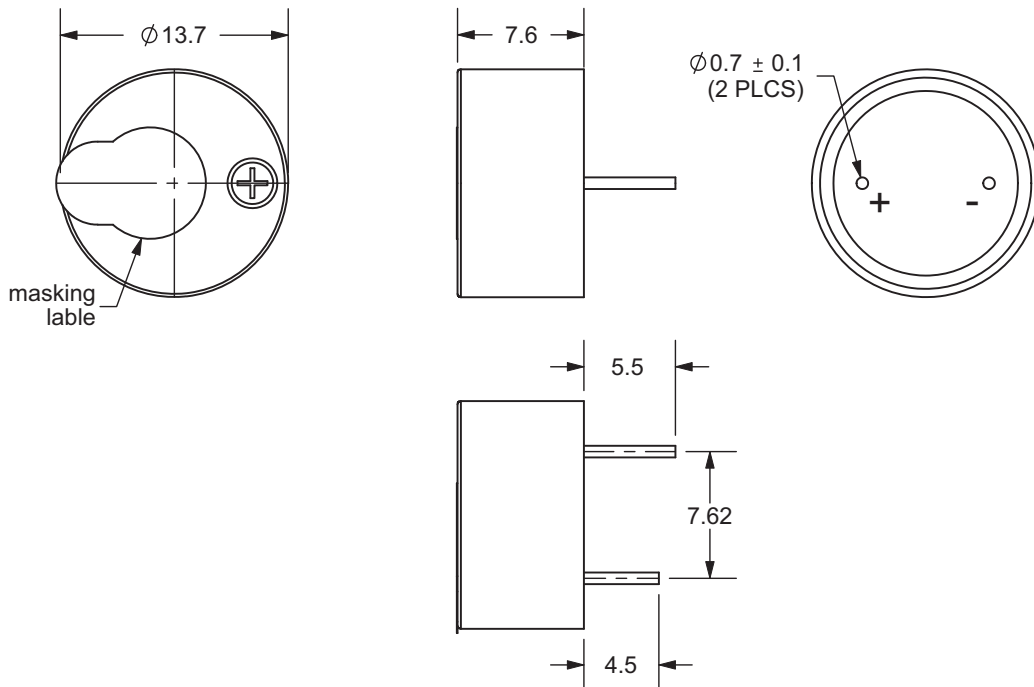

PART NUMBER: CPE-164

DESCRIPTION: piezo audio transducer

FREQUENCY RESPONSE CURVE

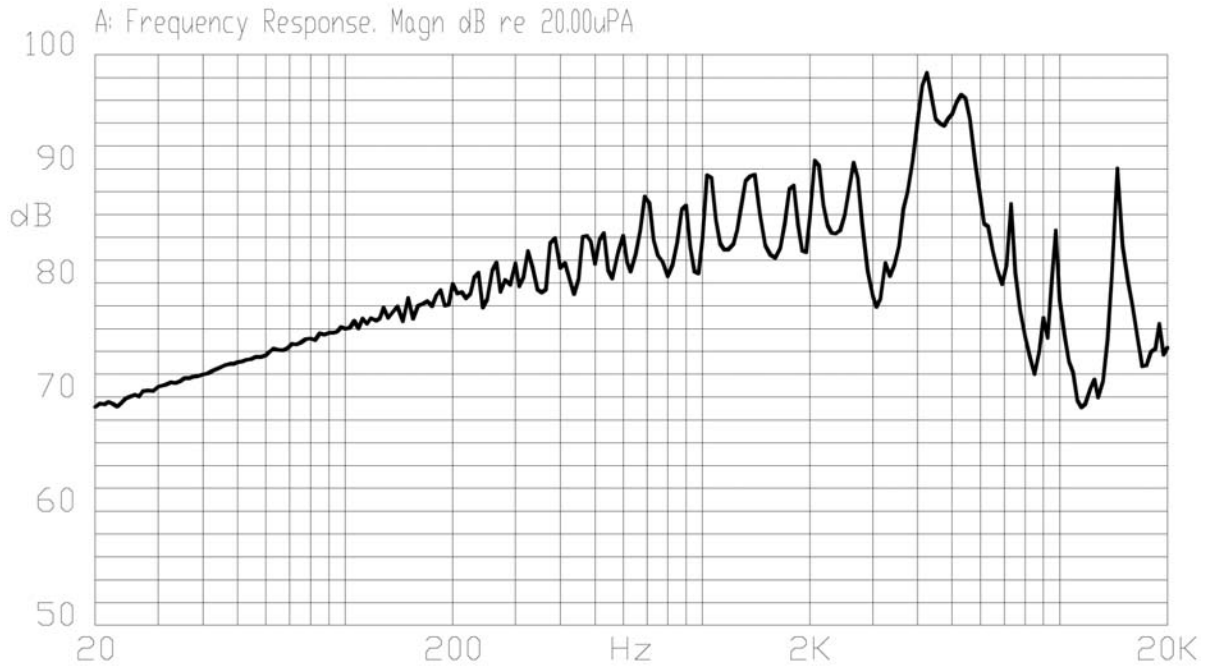

MEASUREMENT METHOD

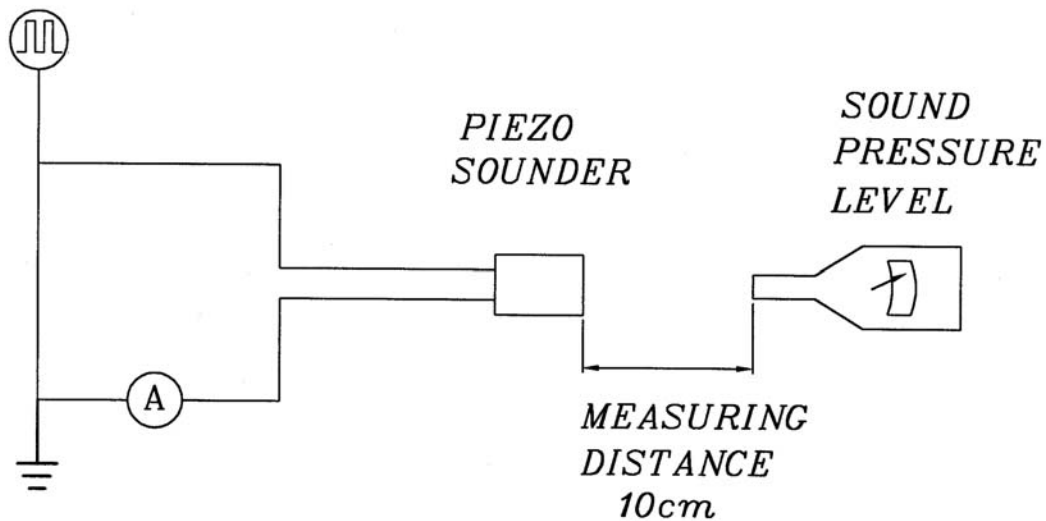

S.P.L. Measuring Circuit
Input Signal: 10 Vp-p, 4.0 KHz, square wave
Mic: RION S.P.L. meter UC30 or equivalent
S.G.: Hewlett Packard 33120A function generator or equivalent



PART NUMBER: CPE-164

DESCRIPTION: piezo audio transducer

MECHANICAL CHARACTERISTICS

item	test condition	evaluation standard
solderability ¹	Lead terminals are immersed in rosin for 5 seconds and then immersed in solder bath of 270 ±5°C for 3 ±1 seconds.	90% min. of the lead terminals will be wet with solder (except the edge of the terminal).
soldering heat resistance	Lead terminals are immersed up to 1.5mm from buzzer's body in solder bath of 300 ±5°C for 3 ±0.5 seconds or 260 ±5°C for 10 ±1 seconds.	No interference in operation.
terminal mechanical strength	For 10 seconds, the force of 9.8N (1.0kg) is applied to each terminal in axial direction.	No damage or cutting off.
vibration	The buzzer shall be measured after applying a vibration amplitude of 1.5 mm with 10 to 55 Hz band of vibration frequency to each of the 3 perpendicular directions for 2 hours.	The value of oscillation frequency/current consumption should be ±10% of the initial measurements. The SPL should be within ±10dB compared with the initial measurement.
drop test	The part will be dropped from a height of 75 cm onto a 40 mm thick wooden board 3 times in 3 axes (X, Y, Z) for a total of 9 drops.	

Notes: 1. Not recommended for wave soldering

ENVIRONMENT TEST

item	test condition	evaluation standard
high temp. test	After being placed in a chamber at +80°C for 240 hours.	The buzzer will be measured after being placed at +25°C for 4 hours. The value of the oscillation frequency/current consumption should be ±10% compared to the initial measurements. The SPL should be within ±10dB compared to the initial measurements.
low temp. test	After being placed in a chamber at -30°C for 240 hours.	
humidity test	After being placed in a chamber at +40°C and 90±5% relative humidity for 240 hours.	
temp. cycle test	The part shall be subjected to 5 cycles. One cycle will consist of:	

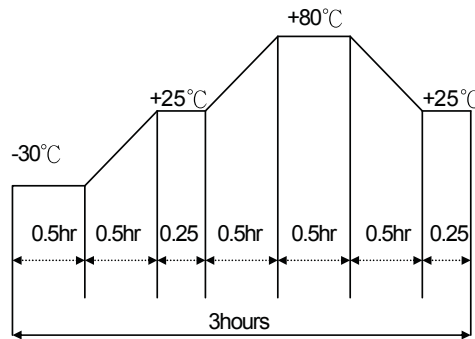



PART NUMBER: CPE-164

DESCRIPTION: piezo audio transducer

RELIABILITY TEST

item	test condition	evaluation standard
operating (life test)	1. Continuous life test: The part will be subjected to 48 hours of continuous operation at +55°C with rated voltage applied. 2. Intermittent life test: A duty cycle of 1 minute on, 1 minutes off, a minimum of 5,000 times at room temp (+25 ±2°C) with rated voltage applied.	The buzzer will be measured after being placed at +25°C for 4 hours. The value of the oscillation frequency/current consumption should be ±10% compared to the initial measurements. The SPL should be within ±10dB compared to the initial measurements.

TEST CONDITIONS

standard test condition	a) temperature: +5 ~ +35°C	b) humidity: 45 - 85%	c) pressure: 860-1060 mbar
judgement test condition	a) temperature: +25 ±2°C	b) humidity: 60 - 70%	c) pressure: 860-1060 mbar

PART NUMBER: CPE-164

DESCRIPTION: piezo audio transducer

PACKAGING

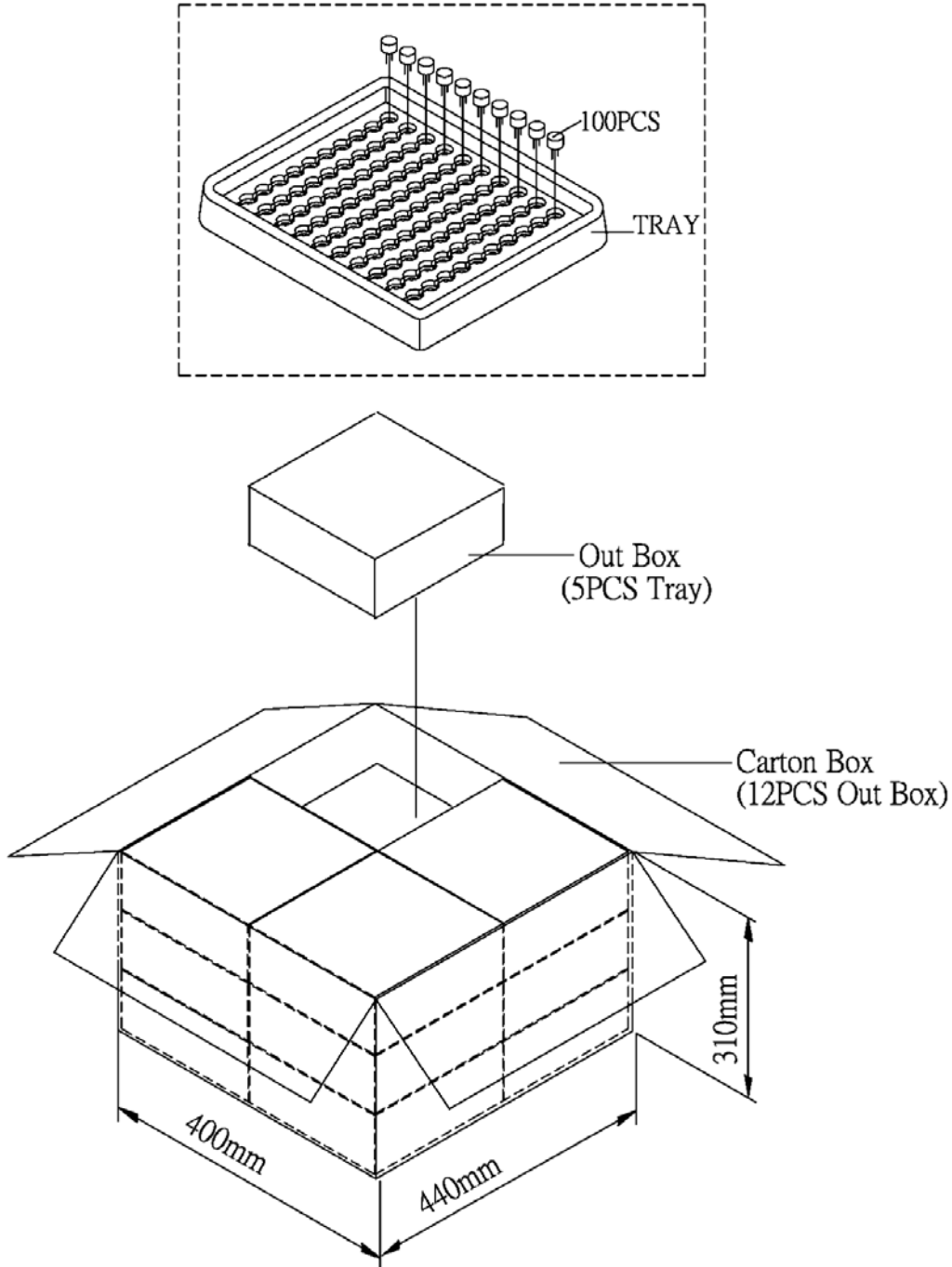

Tray	184mmx180mmx23mm	1x100PCS=100PCS
Out Box	200mmx190mmx100mm	5LAYERx100PCS=500PCS
Carton Box	440mmx400mmx310mm	500PCSx12=6,000PCS