

**MODEL:** CST-931AP | **DESCRIPTION:** MAGNETIC BUZZER TRANSDUCER

**FEATURES**

- top port
- 85 db SPL minimum
- externally driven



**SPECIFICATIONS**

parameter	conditions/description	min	typ	max	units
rated voltage			3.0		Vo-p
operating voltage	0V	2.0		4.0	Vo-p
current consumption	at rated voltage, 2,730 Hz square wave, 1/2 duty			80	mA
rated frequency			2,730		Hz
sound pressure level	at 10 cm (A-weight), rated voltage, 2,730 Hz square wave, 1/2 duty	85	92		dba
coil resistance		12.7	15.0	17.3	Ω
dimensions	∅9.0 x 4.5				mm
weight			0.65		g
material	PBT				
terminal	pin type (Au plating)				
operating temperature		-30		70	°C
storage temperature		-30		80	°C
RoHS	yes				

Notes: 1. All specifications measured at 5~35°C, humidity at 45~85%, under 86~106kPa pressure, unless otherwise noted.

**SOLDERABILITY**

parameter	conditions/description	min	typ	max	units
wave soldering	see wave soldering profile			250	°C

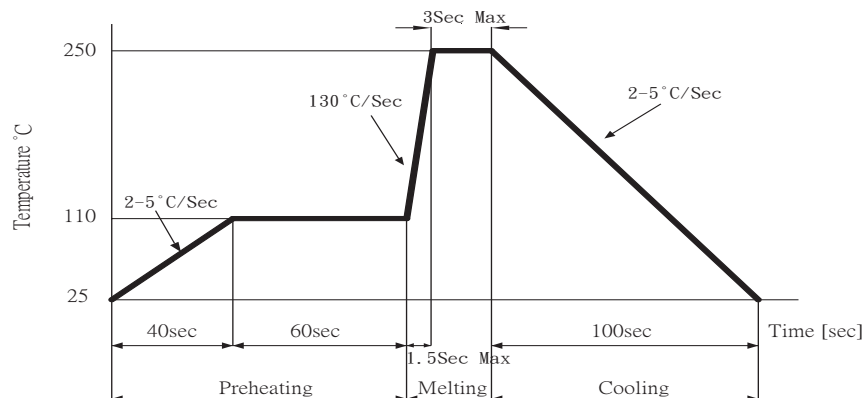

## MECHANICAL DRAWING

units: mm  
tolerance:  $\pm 0.5$  mm

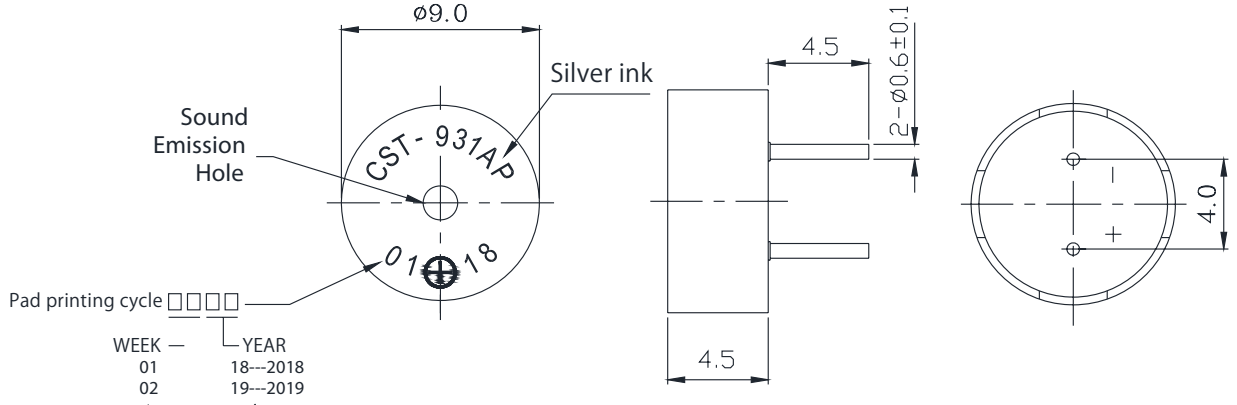

## FREQUENCY RESPONSE CURVE

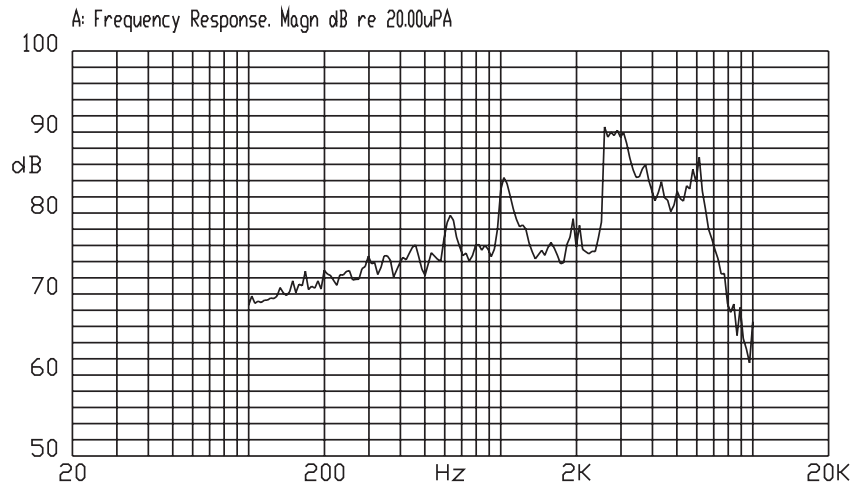

## MEASUREMENT METHOD

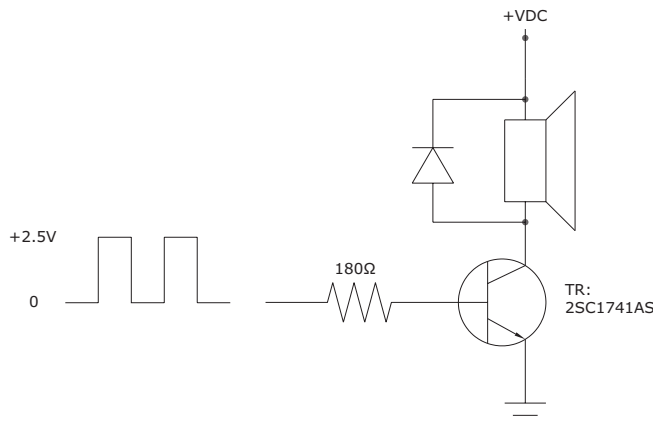

## PACKAGING

Tray Size: 184 x 184 x 23 mm  
 Internal Box Size: 200 x 190 x 100 mm  
 Carton Size: 440 x 400 x 310 mm  
 QTY: 8,400 pcs (100 x 7 x 12)

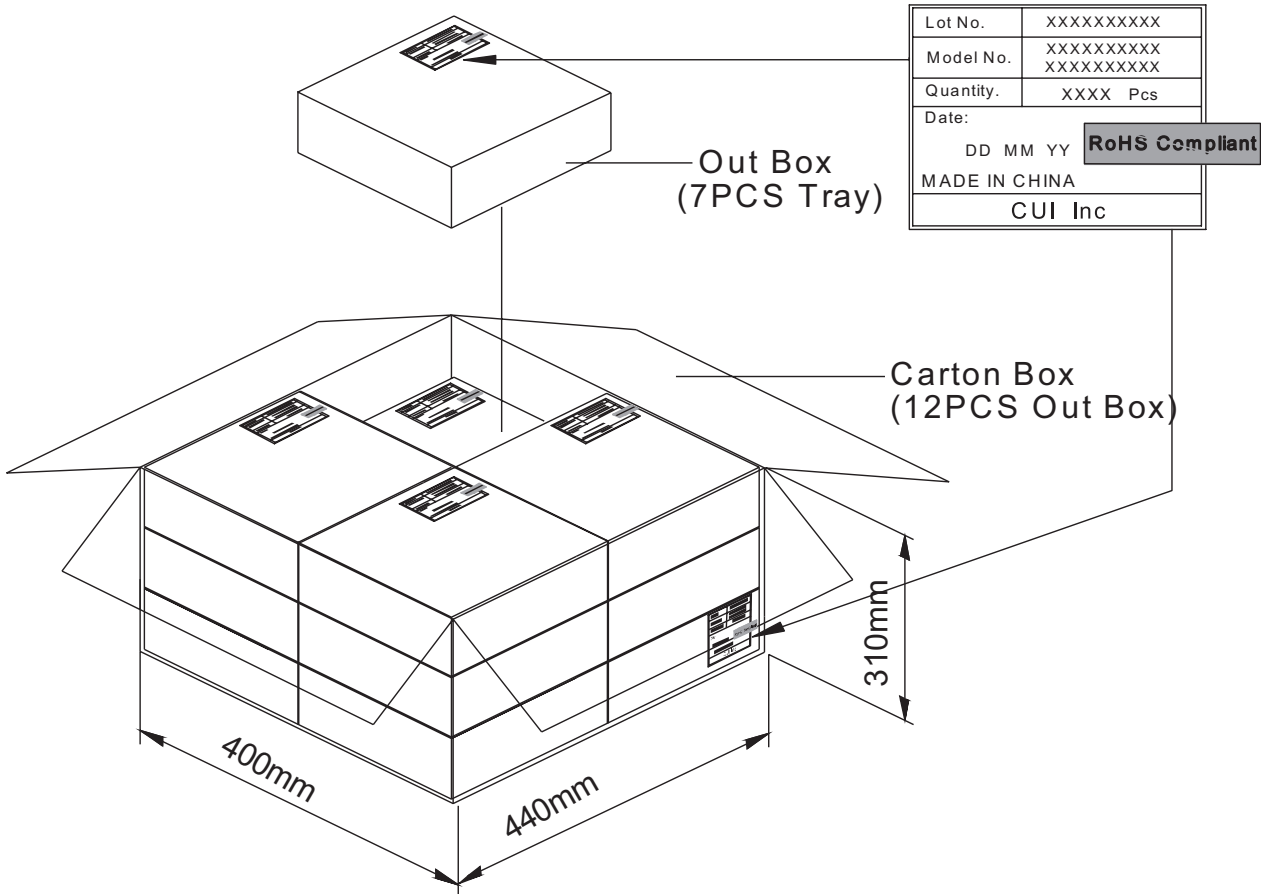
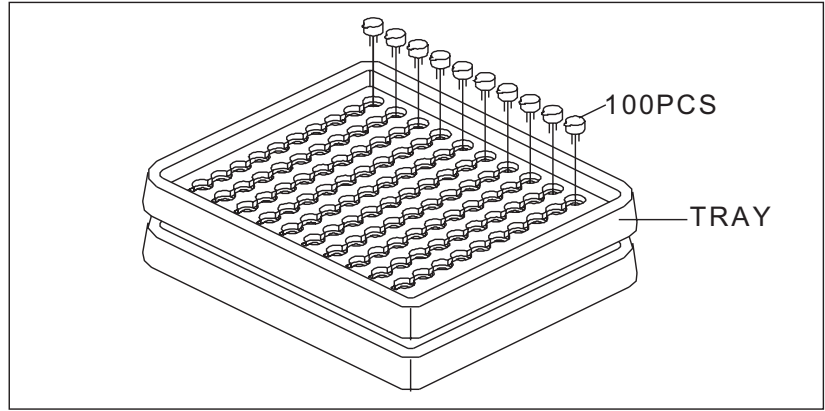

## REVISION HISTORY

---

rev.	description	date
1.0	initial release	01/30/2006
1.01	applied new spec template	01/14/2016
1.02	changed to single plastic housing design	08/27/2018

The revision history provided is for informational purposes only and is believed to be accurate.



**CUI INC**<sup>®</sup>

**Headquarters**  
20050 SW 112th Ave.  
Tualatin, OR 97062  
**800.275.4899**

Fax 503.612.2383  
**cui.com**  
techsupport@cui.com

CUI offers a one (1) year limited warranty. Complete warranty information is listed on our website.

CUI reserves the right to make changes to the product at any time without notice. Information provided by CUI is believed to be accurate and reliable. However, no responsibility is assumed by CUI for its use, nor for any infringements of patents or other rights of third parties which may result from its use.

CUI products are not authorized or warranted for use as critical components in equipment that requires an extremely high level of reliability. A critical component is any component of a life support device or system whose failure to perform can be reasonably expected to cause the failure of the life support device or system, or to affect its safety or effectiveness.