

DO NOT SCALE FROM THIS PRINT

NOTES:

- HIDDEN LINES ARE USED TO SHOW POLARIZATION WHEN USING -N OPTION.
- ⊗ REPRESENTS A CRITICAL DIMENSION.
- AS OF REV 'C' ON TCB-50 CABLE ASSEMBLIES WILL BE LEAD FREE.
- ALL ASSEMBLIES TO BE 100% ELECTRICALLY TESTED FOR SHORTS AND OPENS.
- ALL ASSEMBLIES TO BE 100% HI-POT TESTED AT 800V.
- STRAIN RELIEF TO WITHSTAND 5LB STRAIGHT PULL.
- WHEN CUTTING CABLE TO LENGTH, CONDUCTORS MAY NOT EXTEND PAST THE CABLE INSULATION.
- REFERENCE TCSD-XX-XX-X-XXX PRINT FOR CONNECTOR ASSEMBLY AND ITS REQUIREMENTS.
- WHEN CUTTING CABLE TO LENGTH, CONDUCTORS SHOULD NOT EXTEND PAST THE CABLE INSULATION, EXTENDING LESS THAN 25% OF CABLE THICKNESS ON CONSECUTIVE AND LESS THAN 50% OF THE CABLE THICKNESS ON NON-CONSECUTIVE STRANDS IS CONSIDERED A PROCESS INDICATOR.
- FOR LENGTHS LESS THAN 12.5" TOLERANCE SHALL BE +/- .125, ALL OTHER LENGTHS SHALL BE +/- 1%.

TCSD-XX-X-XX.XX-01-X-XXX-XXX

No OF POSITIONS

03, 04, 05, 07, 08, 10, 12, 13, 15, 17, 20, 22, 25  
NOTE: OTHER POSITIONS AVAILABLE AS ASO. TOOL IS CAPABLE OF POSITIONS 2-25

END ASSEMBLY

-S: SINGLE  
-D: DOUBLE

ASSEMBLY LENGTH

-D"XX", -R, -M & -O OPTION: 2.00[50.8] MINIMUM  
ALL OTHER OPTION: 1.00[25.4] MINIMUM

OPTIONS #2  
SEE OPTIONS BELOW

OPTIONS #1  
SEE OPTIONS BELOW

PLATING OPTION

-F: FLASH SELECTIVE GOLD, MATTE TIN TAIL  
-L: LIGHT SELECTIVE GOLD, MATTE TIN TAIL  
(LEAVE BLANK FOR STANDARD -S: SELECTIVE PLATING)

LEAD STYLE

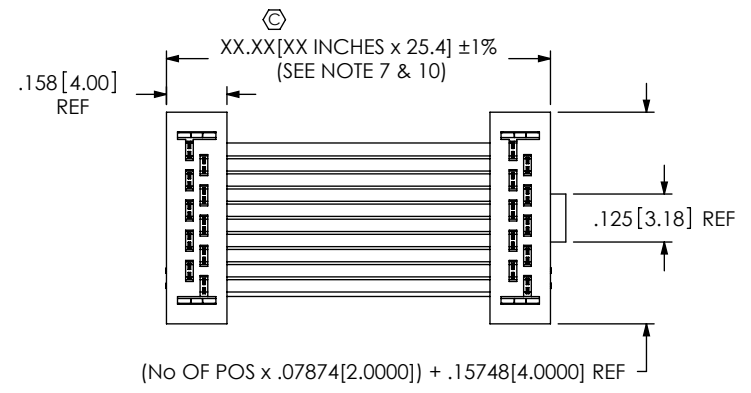
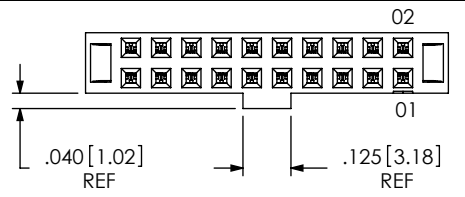
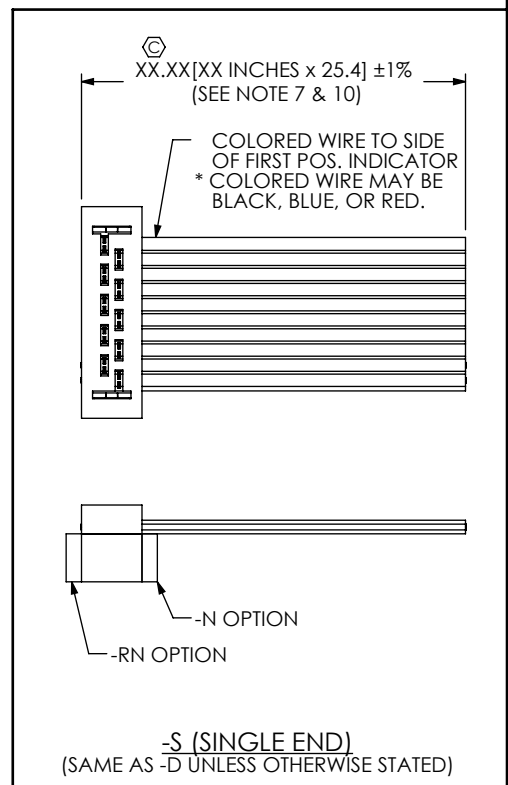
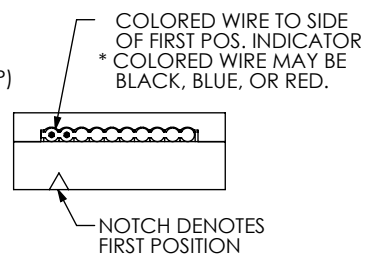
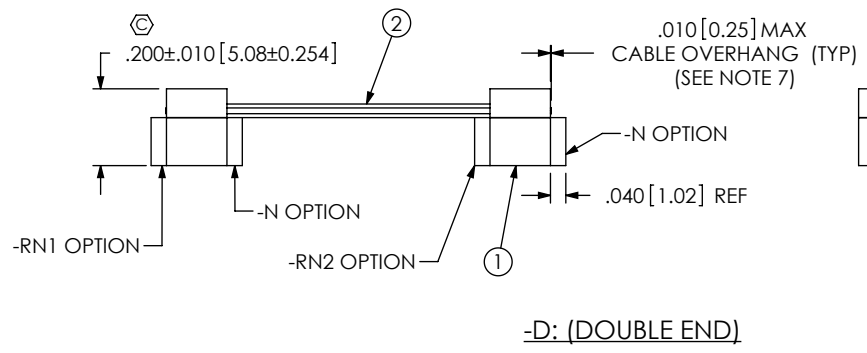
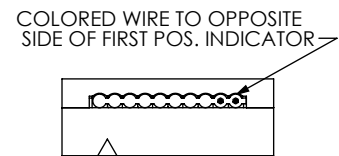

TABLE 1	
ITEM #	PART
1	TCSD-XX-XX-XXX
2	TCB-50
3	TFB-XX-D-XX-X
4	TMSR-XX
5	C-57-X
6	TMC-XX-D



-N: NOTCH POLARIZATION  
(USE TCSD-XX-XX-N)  
(AVAILABLE ON POS 04 THRU 25)



-RW: REVERSE WIRING  
(NOT AVAILABLE WITH -RN1 OR -RN2 OPTIONS)

F:\DWG\MISC\MKTG\TCSD-XX-X-XX.XX-01-X-XXX-XXX-MKT.SLDDRW

UNLESS OTHERWISE SPECIFIED, DIMENSIONS ARE IN INCHES.  
TOLERANCES ARE:  
DECIMALS ANGLES  
.XX: ±.01 [.3] 2°  
.XXX: ±.005 [.13]  
.XXXX: ±.0020 [.051]

**PROPRIETARY NOTE**  
THIS DOCUMENT CONTAINS CONFIDENTIAL AND PROPRIETARY INFORMATION AND ALL DESIGN, MANUFACTURING, REPRODUCTION, USE, PATENT RIGHTS AND SALES RIGHTS ARE EXPRESSLY RESERVED BY SAMTEC, INC. THIS DOCUMENT SHALL NOT BE DISCLOSED, IN WHOLE OR PART, TO ANY UNAUTHORIZED PERSON OR ENTITY NOR REPRODUCED, TRANSFERRED OR INCORPORATED IN ANY OTHER PROJECT IN ANY MANNER WITHOUT THE EXPRESS WRITTEN CONSENT OF SAMTEC, INC.

**MATERIAL:** DO NOT SCALE DRAWING SHEET SCALE: 2:1  
INSULATOR: BLACK PBT  
CONTACT: HEAT TREATED BeCu  
STRAIN RELIEF: BLACK PBT  
WIRE: 28 AWG, 7/36, TINNED, COPPER WITH PVC INSULATOR  
**PLATING:**  
-L: .000015 GOLD ON CONTACT AREA, TIN ON REMAINDER  
-F: .000003 GOLD ON CONTACT AREA, TIN ON REMAINDER  
(STANDARD PLATING IS .000030 GOLD ON CONTACT AREA, TIN ON REMAINDER)

520 PARK EAST BLVD, NEW ALBANY, IN 47150  
PHONE: 812-944-6733 FAX: 812-948-5047  
e-Mail: info@SAMTEC.com code 55322

DESCRIPTION:  
**2MM DOUBLE ROW FEMALE IDC ASSEMBLY**  
DWG. NO.  
**TCSD-XX-X-XX.XX-01-X-XXX-XXX**  
BY: B RAY 11/20/2007 SHEET 1 OF 3

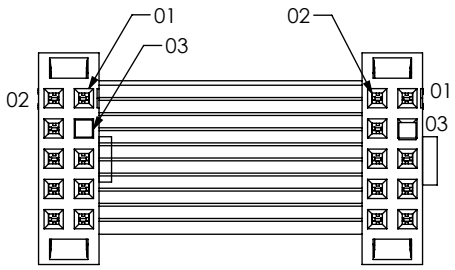

-P"XX": POLARIZED MATING

NOTE: THE SAME POSITION WILL BE POLARIZED ON BOTH ENDS (USE PK-07-N)

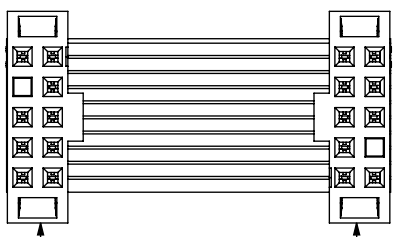

TCSD-05-D-XX-01-RN2 SHOWN

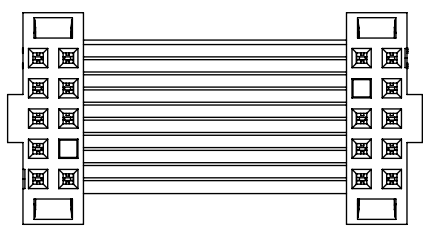

TCSD-05-D-XX-01-RN1 SHOWN

-RN1 OR -RN2 (REVERSE POLARIZATION NOTCH)

NOTE:  
 -RN1 = REVERSE NOTCH ON 1ST CONNECTOR ONLY AVAILABLE FOR POSITIONS 4 OR GREATER (NOT AVAILABLE WITH -R OR -RW OPTIONS)  
 -RN2 = REVERSE NOTCH ON 2ND CONNECTOR ONLY (NOT AVAILABLE WITH -R OR -RW OPTIONS)  
 (REVERSE NOTCH NOT AVAILABLE WITH DAISY CHAIN OPTIONS)

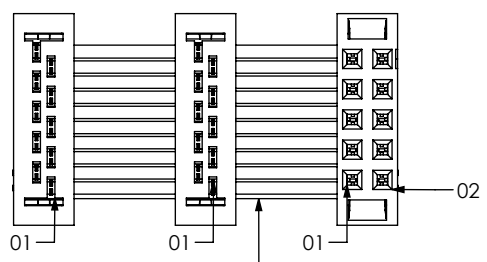

COLORED WIRE TO SIDE OF FIRST POS. INDICATOR  
 \* COLORED WIRE MAY BE BLACK, BLUE, OR RED.

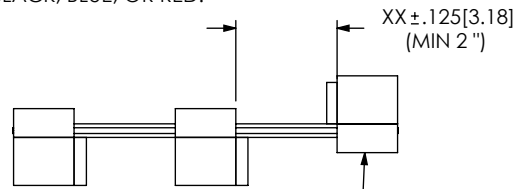

OUTSIDE SOCKET REVERSED WHEN DAISY CHAINED

-O: OUTSIDE REVERSED (NOT AVAILABLE WITH -R OR -M) (MINIMUM 2.00[50.8], 1.00[25.4] INCREMENTS)

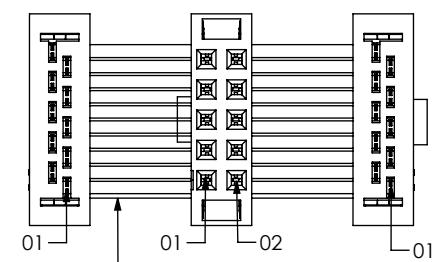

COLORED WIRE TO SIDE OF FIRST POS. INDICATOR  
 \* COLORED WIRE MAY BE BLACK, BLUE, OR RED.

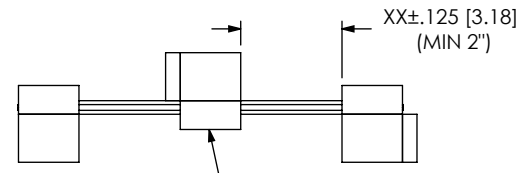

MIDDLE SOCKET REVERSED WHEN DAISY CHAINED

-M: MIDDLE REVERSED (NOT AVAILABLE WITH -R OR -O) (MINIMUM 2.00[50.8], 1.00[25.4] INCREMENTS)

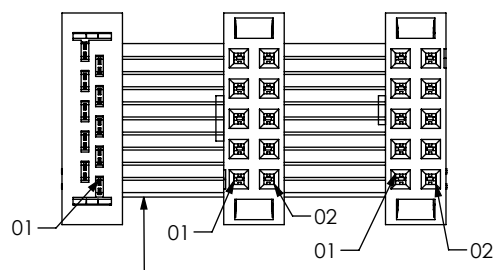

COLORED WIRE TO SIDE OF FIRST POS. INDICATOR  
 \* COLORED WIRE MAY BE BLACK, BLUE, OR RED.

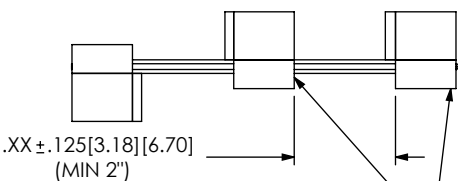

BOTH SOCKETS REVERSED WHEN DAISY CHAINED

-R: REVERSE CONNECTOR (NOT AVAILABLE WITH -O, -M, -RN1 OR -RN2 OPTION) (MINIMUM 2.00[50.8], 1.00[25.4] INCREMENTS)

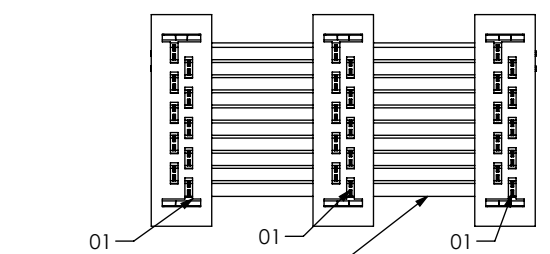

COLORED WIRE TO SIDE OF FIRST POS. INDICATOR  
 \* COLORED WIRE MAY BE BLACK, BLUE, OR RED.

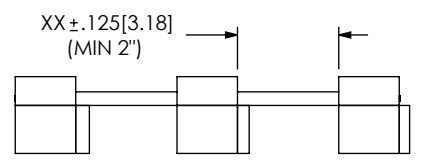

-D"XX": DAISY CHAINED (2" MIN LENGTH, 1" INCREMENTS ONLY)

**PROPRIETARY NOTE**  
 THIS DOCUMENT CONTAINS CONFIDENTIAL AND PROPRIETARY INFORMATION AND ALL DESIGN, MANUFACTURING, REPRODUCTION, USE, PATENT RIGHTS AND SALES RIGHTS ARE EXPRESSLY RESERVED BY SAMTEC, INC. THIS DOCUMENT SHALL NOT BE DISCLOSED, IN WHOLE OR PART, TO ANY UNAUTHORIZED PERSON OR ENTITY NOR REPRODUCED, TRANSFERRED OR INCORPORATED IN ANY OTHER PROJECT IN ANY MANNER WITHOUT THE EXPRESS WRITTEN CONSENT OF SAMTEC, INC.

DO NOT SCALE DRAWING  
 SHEET SCALE: 2:1



520 PARK EAST BLVD, NEW ALBANY, IN 47150  
 PHONE: 812-944-6733 FAX: 812-948-5047  
 e-Mail: info@SAMTEC.com code 55322

DESCRIPTION:  
 2MM DOUBLE ROW FEMALE IDC ASSEMBLY

DWG. NO.  
 TCSD-XX-X-XX.XX-01-X-XXX-XXX

BY: B RAY 11/20/2007 SHEET 2 OF 3

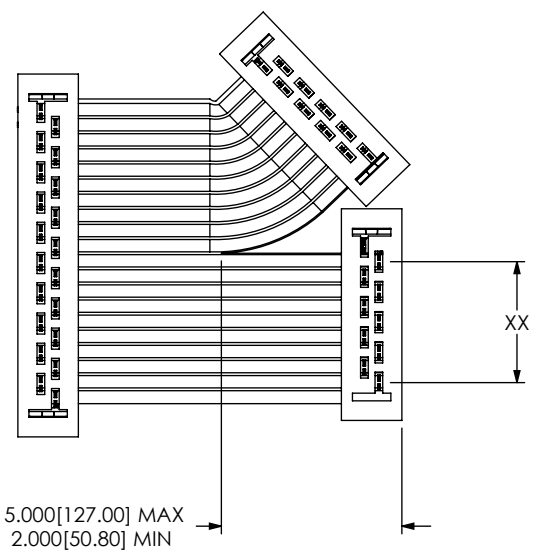

**-B"XX": BREAKOUT OPTION**  
(TCSD-10-D-XX.XX-01-X-B05 SHOWN)

"XX" = NO. OF CONDUCTORS BROKEN OUT FROM THE FIRST POSITION.  
AN EVEN NUMBER POSITION BREAKOUT MUST BE SELECTED FOR A DOUBLE ENDED ASSEMBLY  
AND THE BREAKOUT ENDS MUST BE EQUAL TO THE FULL POSITION CONNECTOR.

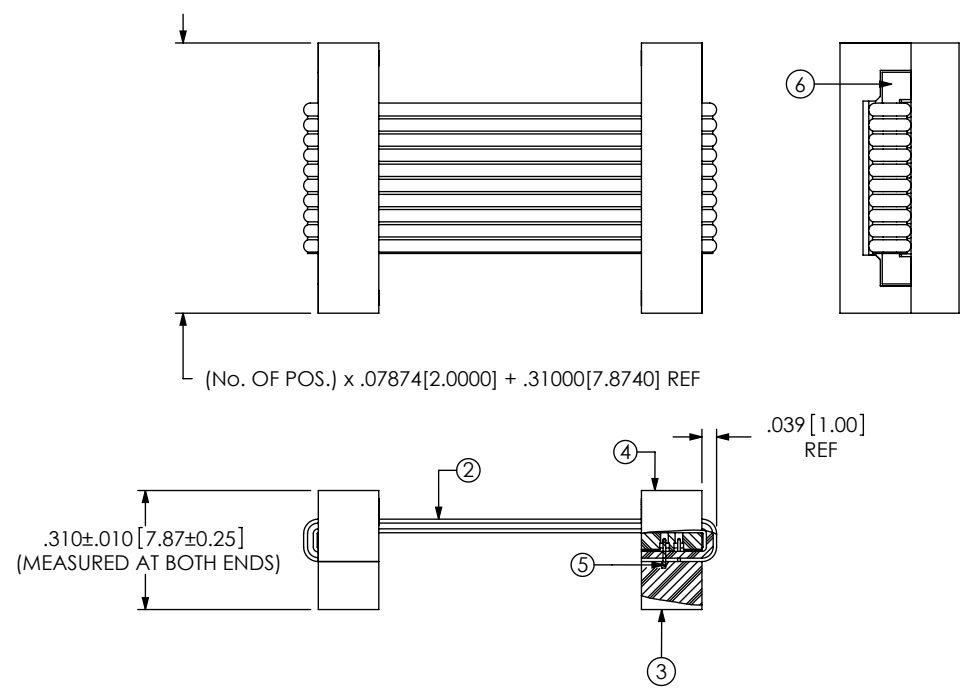

**-SR: STRAIN RELIEF**  
(NOT AVAILABLE WITH -O, -M, -R, -D"XX" OR -B"XX")  
(SAME AS -D, UNLESS OTHERWISE STATED)  
(SOLD IN ASSEMBLIES ONLY)  
(MUST USE HEAT BEND/STRAIN RELIEF TOOL ON POSITIONS 20-25)

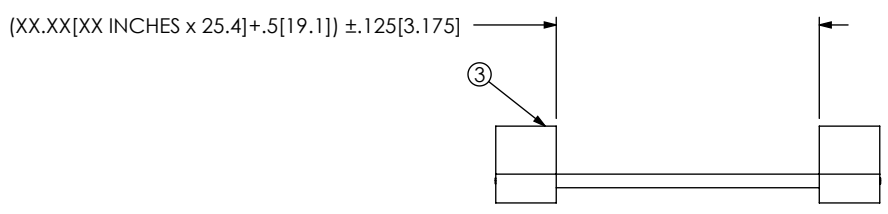

**IN-PROCESS 1**  
(-SR ONLY)

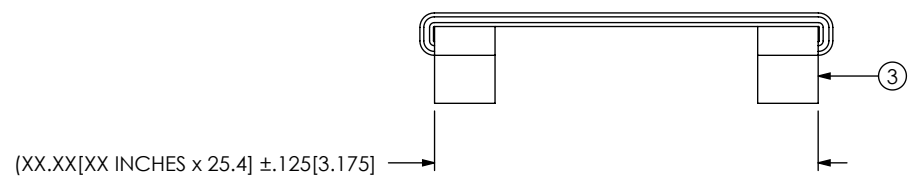

**IN-PROCESS 2**  
(-SR ONLY)

**PROPRIETARY NOTE**  
THIS DOCUMENT CONTAINS CONFIDENTIAL AND PROPRIETARY INFORMATION AND ALL DESIGN, MANUFACTURING, REPRODUCTION, USE, PATENT RIGHTS AND SALES RIGHTS ARE EXPRESSLY RESERVED BY SAMTEC, INC. THIS DOCUMENT SHALL NOT BE DISCLOSED, IN WHOLE OR PART, TO ANY UNAUTHORIZED PERSON OR ENTITY NOR REPRODUCED, TRANSFERRED OR INCORPORATED IN ANY OTHER PROJECT IN ANY MANNER WITHOUT THE EXPRESS WRITTEN CONSENT OF SAMTEC, INC.

DO NOT SCALE DRAWING

SHEET SCALE: 2:1



520 PARK EAST BLVD. NEW ALBANY, IN 47150  
PHONE: 812-944-6733 FAX: 812-948-5047  
e-Mail: info@SAMTEC.com code 55322

DESCRIPTION:  
**2MM DOUBLE ROW FEMALE IDC ASSEMBLY**

DWG. NO.  
**TCSD-XX-X-XX.XX-01-X-XXX-XXX**

BY: B RAY 11/20/2007 SHEET 3 OF 3